



(19) **United States**
(12) **Patent Application Publication**
YOU et al.

(10) **Pub. No.: US 2015/0041768 A1**
(43) **Pub. Date: Feb. 12, 2015**

(54) **ORGANIC LIGHT-EMITTING DISPLAY APPARATUS**

Publication Classification

(71) Applicant: **Samsung Display Co., Ltd.**,
Yongin-City (KR)

(51) **Int. Cl.**
H01L 27/32 (2006.01)

(72) Inventors: **JAE-HO YOU**, Yongin-City (KR);
Myung-Im Kim, Yongin-City (KR);
Seung-Won Park, Yongin-City (KR);
Lei Xie, Yongin-City (KR); **Moon-Gyu Lee**,
Yongin-City (KR); **Su-Mi Lee**,
Yongin-City (KR)

(52) **U.S. Cl.**
CPC **H01L 27/3262** (2013.01)
USPC **257/40**

(73) Assignee: **Samsung Display Co., Ltd.**,
Yongin-City (KR)

(57) **ABSTRACT**

An organic light-emitting display apparatus includes a first emission portion and an optical member. The first emission portion emits light of a first color, and includes a first intermediate layer, a first electrode that is disposed on one surface of the first intermediate layer and transmits light emitted from the first intermediate layer, and a second electrode that is disposed on another surface of the first intermediate layer facing the one surface of the first intermediate layer and transmits the light emitted from the first intermediate layer. The optical member is disposed on one surface of the first emission portion and selectively reflects light of particular colors including at least the first color light.

(21) Appl. No.: **14/153,960**

(22) Filed: **Jan. 13, 2014**

(30) **Foreign Application Priority Data**

Aug. 12, 2013 (KR) 10-2013-0095607

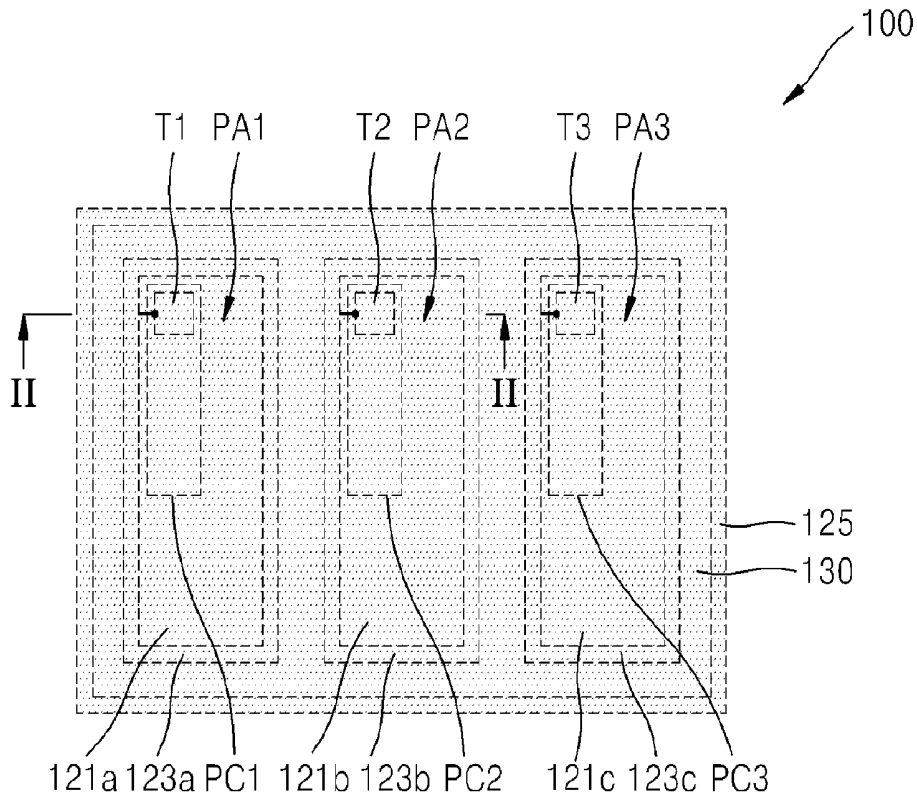

FIG. 1

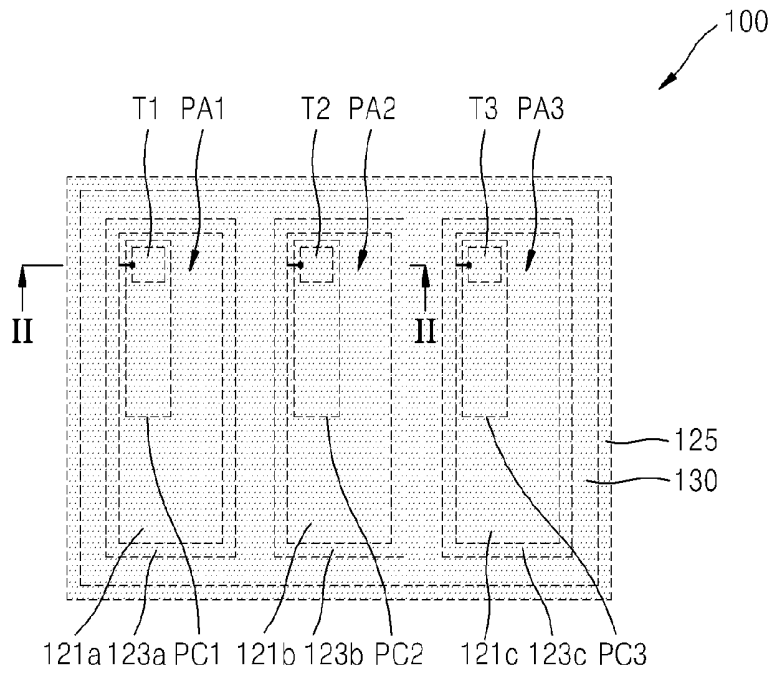

FIG. 2

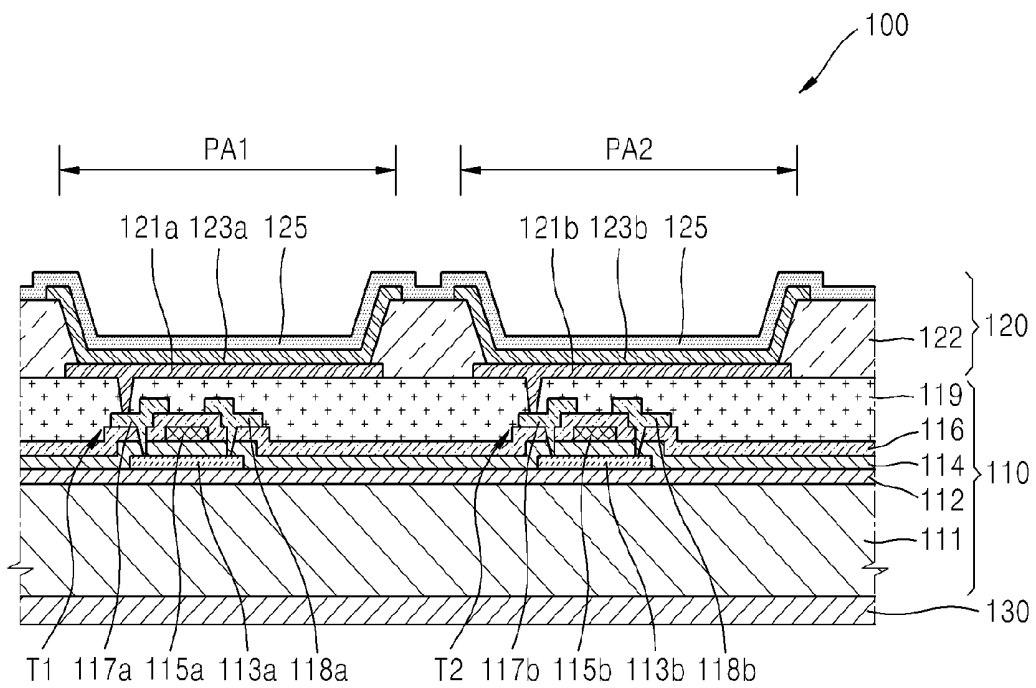

FIG. 3

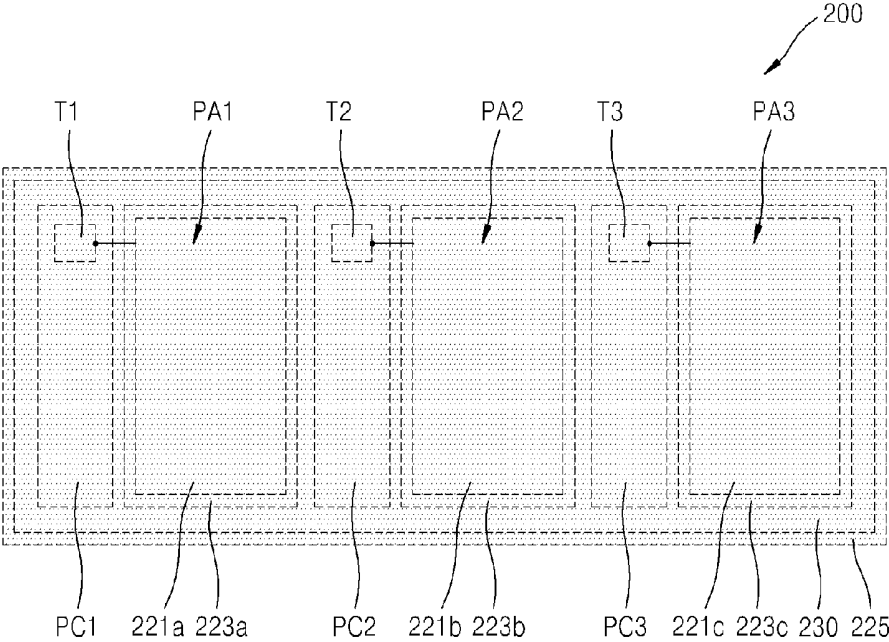

FIG. 4

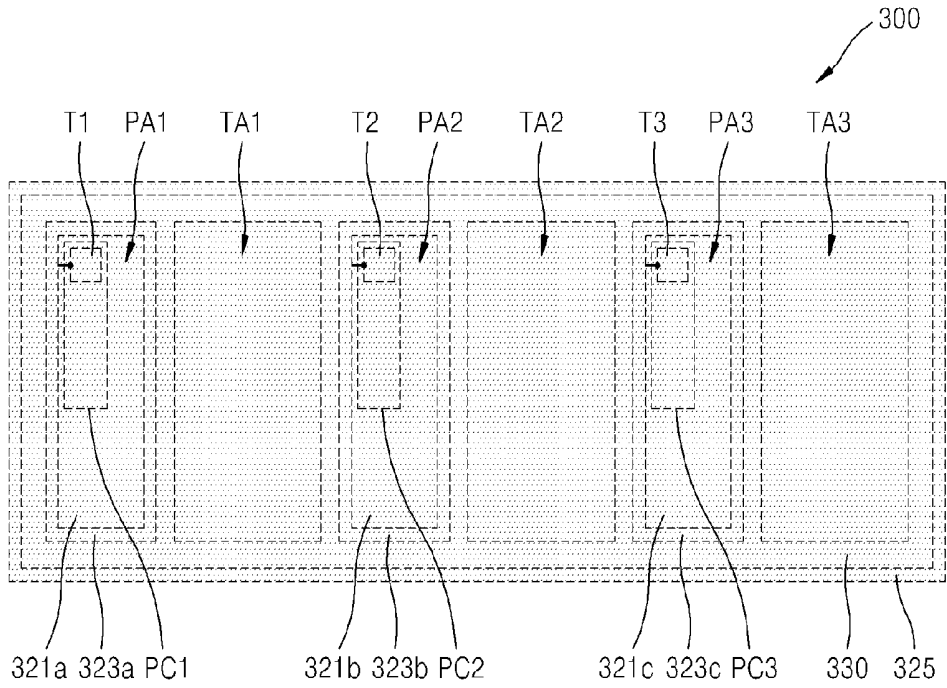

FIG. 5

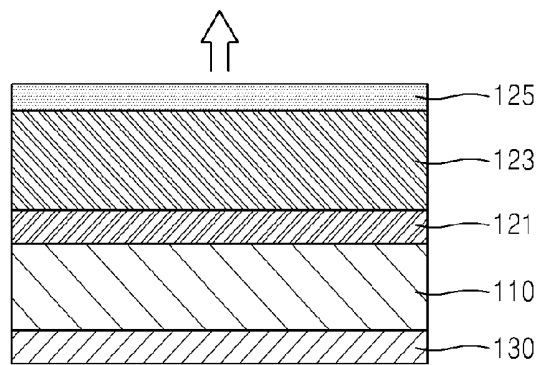

FIG. 6

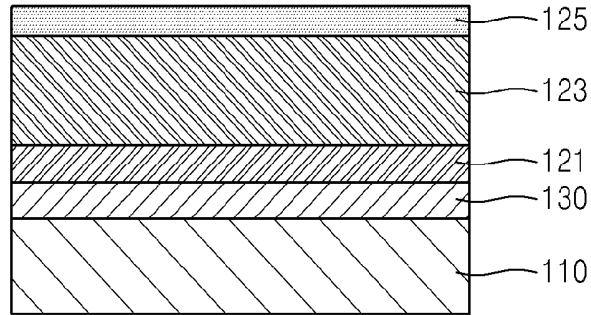

FIG. 7

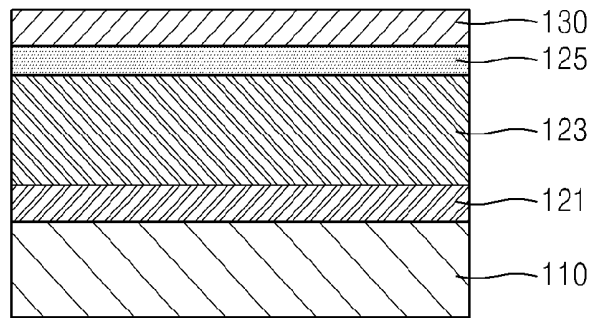

FIG. 8

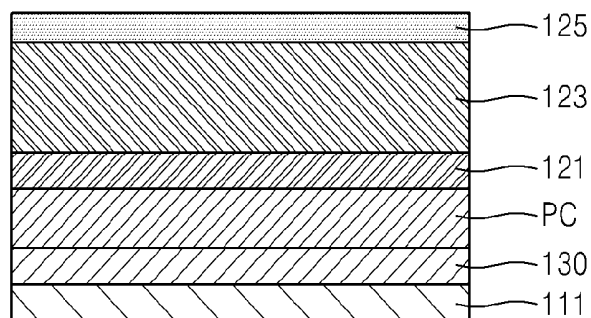

FIG. 9

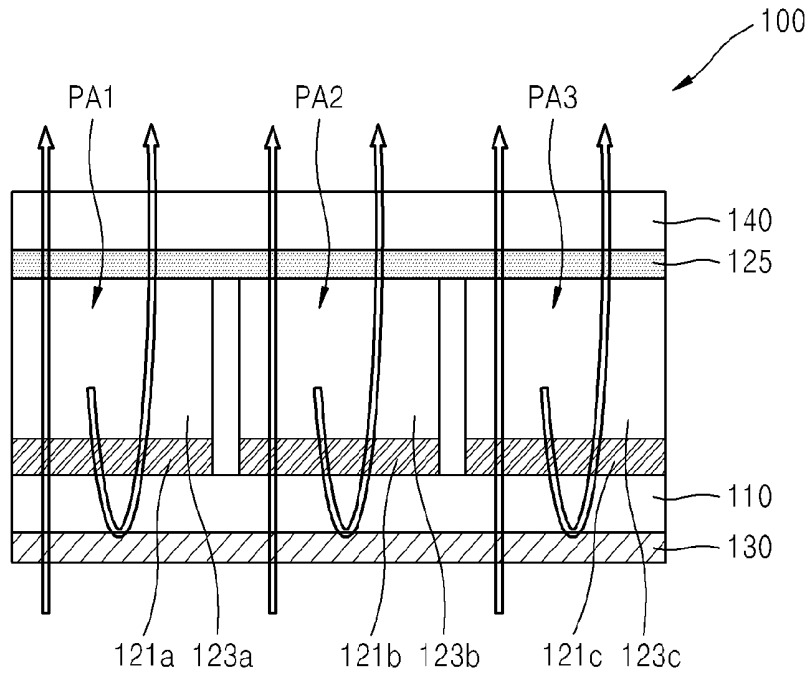

FIG. 10

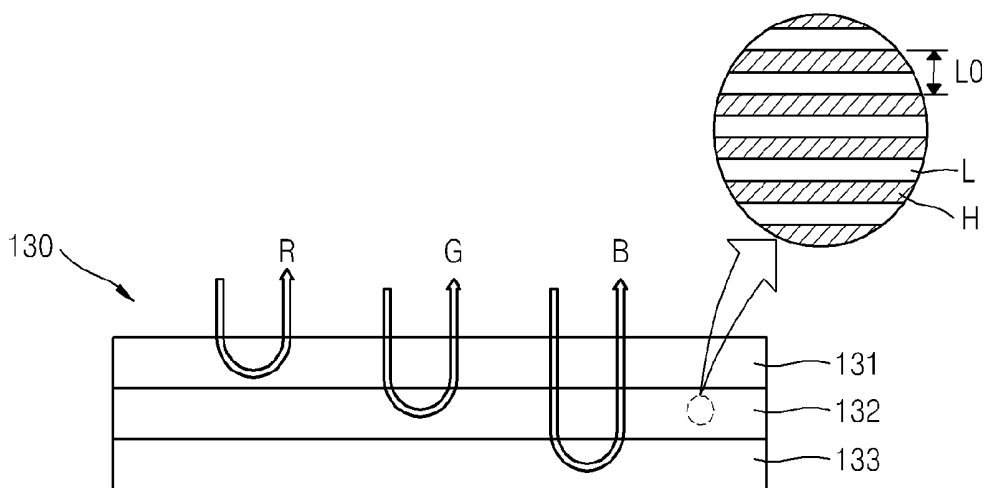

FIG. 11

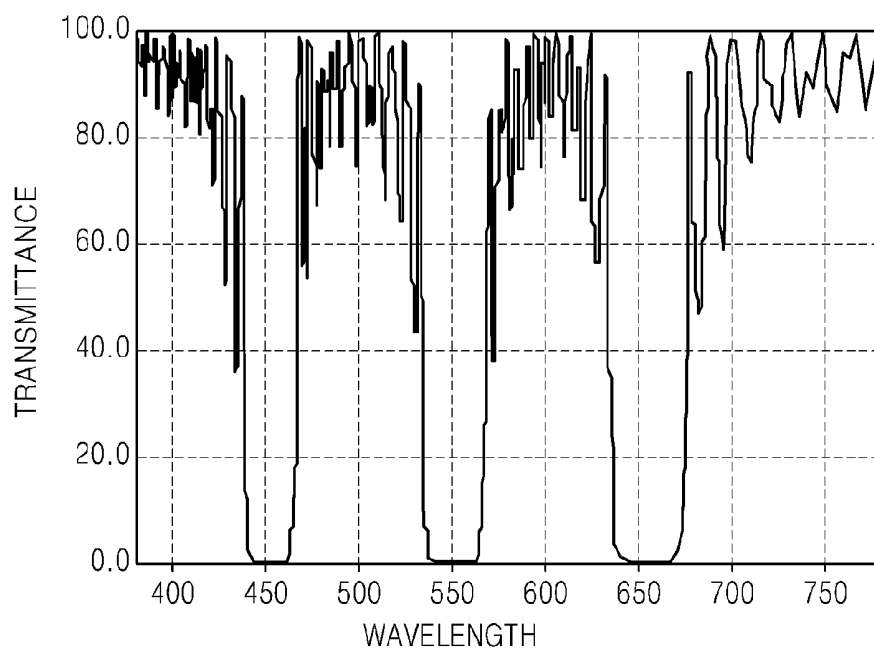

FIG. 12

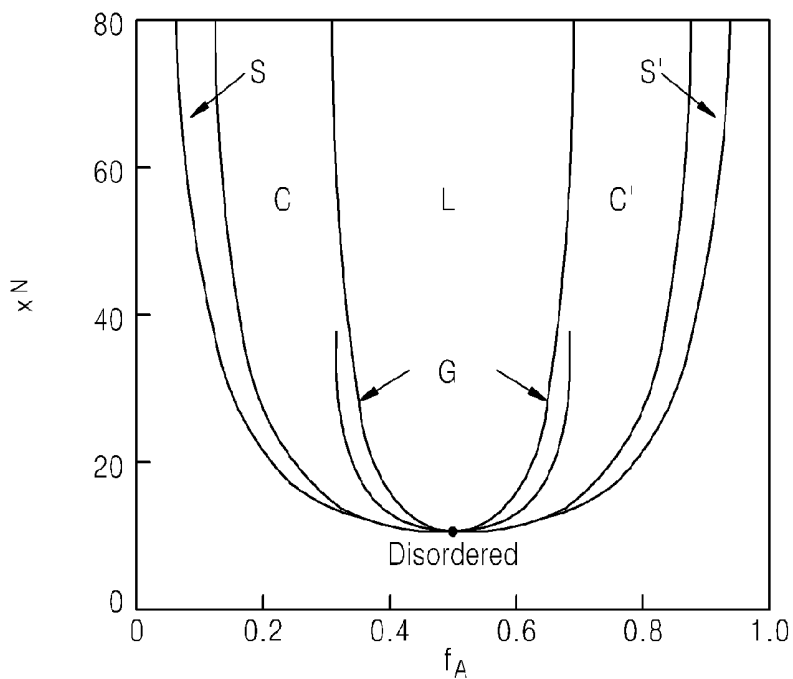

FIG. 13

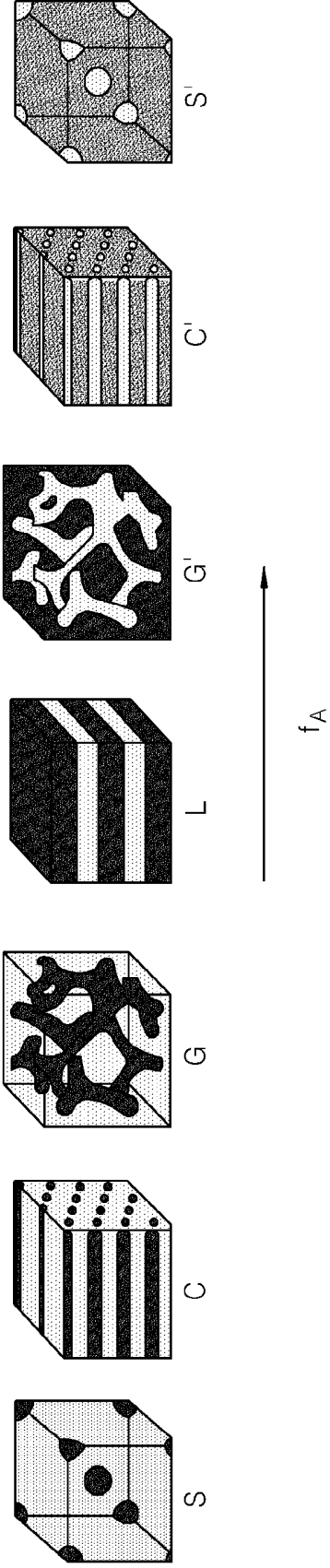
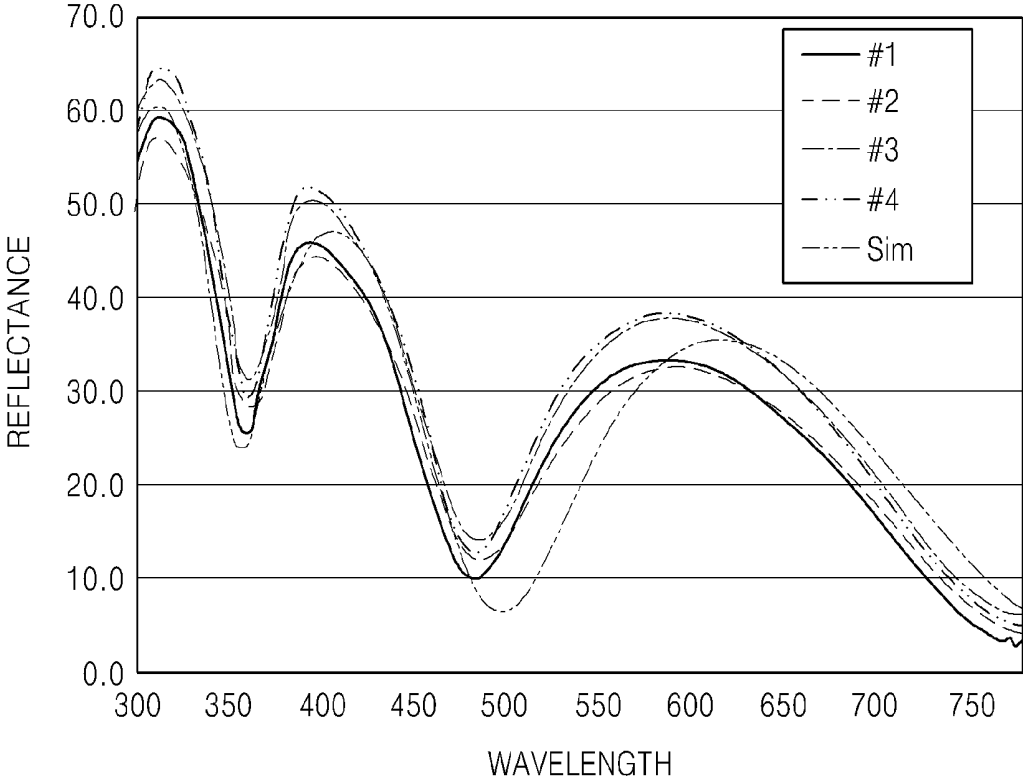

FIG. 14



ORGANIC LIGHT-EMITTING DISPLAY APPARATUS

RELATED APPLICATIONS

[0001] This application claims priority to Korean Patent Application No. 10-2013-0095607, filed on Aug. 12, 2013, in the Korean Intellectual Property Office, the disclosure of which is herein incorporated by reference in its entirety.

TECHNICAL FIELD

[0002] The present disclosure relates to a display apparatus and, more specifically, to an organic light-emitting display apparatus.

DISCUSSION OF THE RELATED ART

[0003] An organic light-emitting display apparatus is a self-luminous display apparatus which includes a plurality of organic light-emitting devices. Each of the organic light-emitting devices includes a hole injection electrode, an electron injection electrode, and an organic emission layer provided therebetween. An exciton is generated when a hole injected from the hole injection electrode is recombined with an electron injected from the electron injection electrode in the organic emission layer. Light is emitted when the exciton falls from an excited state to a ground state.

[0004] Since the organic light-emitting display apparatus is a self-luminous display apparatus, a separate light source is unnecessary. Therefore, the organic light-emitting display apparatus may be driven at a relatively low voltage and may be manufactured to have a light weight and a slim profile. In addition, the organic light-emitting display apparatus has high-grade characteristics, such as wide viewing angles, high contrast, and fast response times. Hence, the organic light-emitting display apparatus has been widely applied to various fields, including personal portable devices such as media players including MP3 players, mobile phones including smartphones, televisions (TVs), and the like.

[0005] Moreover, the organic light-emitting display apparatus may be implemented as a transparent organic light-emitting display apparatus including a transparent region in at least a portion thereof.

SUMMARY

[0006] According to one or more exemplary embodiments of the present invention, an organic light-emitting display apparatus includes a first emission portion including a first intermediate layer. A first electrode is disposed on one surface of the first intermediate layer and transmits light emitted from the first intermediate layer. A second electrode is disposed on another surface of the first intermediate layer facing the one surface of the first intermediate layer and transmits the light emitted from the first intermediate layer. The first emission portion is configured to emit light of a first color. An optical member is disposed on one surface of the first emission portion and selectively reflects light of particular colors including at least the first color.

[0007] The organic light-emitting display apparatus may further include a second emission portion that is disposed adjacent to the first emission portion, without overlapping the first emission portion, and may include a second intermediate layer. The second emission portion is configured to emit light of a second color. A third emission portion is disposed adjacent to the second emission portion, without overlapping the

first emission portion and the second emission portion, and may include a third intermediate layer. The third emission portion is configured to emit light of a third color. The optical member extends from the first emission portion to the second emission portion and the third emission portion, and selectively reflects the light of the first color, the light of the second color, and the light of the third color.

[0008] The first electrode may include indium tin oxide (ITO), indium zinc oxide (IZO), zinc oxide (ZnO), indium oxide (In_2O_3), indium gallium oxide (IGO), and/or aluminum zinc oxide (AZO) as a material transmitting the light emitted from the first emission portion. The second electrode may include a magnesium (Mg) thin film, a silver (Ag) thin film, and/or an Mg:Ag thin film as a material transmitting the light emitted from the first emission portion.

[0009] A substrate may be disposed between the first electrode and the optical member.

[0010] A substrate may be disposed on an opposite surface to a surface of the first electrode where the first intermediate layer is disposed, and the optical member may be disposed between the first electrode and the substrate.

[0011] A thin film transistor (TFT) array substrate may be disposed on an opposite surface to a surface of the first electrode where the first intermediate layer is disposed. The TFT array substrate may include a transparent substrate and a circuit portion. The circuit portion may be disposed on the transparent substrate and may include a TFT. The optical member may be disposed between the transparent substrate and the circuit portion.

[0012] A TFT array substrate may be disposed on an opposite surface to a surface of the first electrode where the first intermediate layer is disposed, and the optical member may be disposed on an opposite surface to a surface of the second electrode where the first intermediate layer is disposed.

[0013] The optical member may include a first color light reflection portion, a second color light reflection portion, and a third color light reflection portion.

[0014] The organic light-emitting display apparatus may further include a first circuit portion, a second circuit portion, and a third circuit portion electrically connected to the first emission portion, the second emission portion, and the third emission portion, respectively. The first circuit portion, the second circuit portion, and the third circuit portion may be disposed not to overlap the first emission portion, the second emission portion, or the third emission portion.

[0015] The organic light-emitting display apparatus may further include a first circuit portion, a second circuit portion, and a third circuit portion electrically connected to the first emission portion, the second emission portion, and the third emission portion, respectively. The first circuit portion, the second circuit portion, and the third circuit portion may be disposed to overlap the first emission portion, the second emission portion, and the third emission portion, respectively.

[0016] The organic light-emitting display apparatus may further include a first transmission portion that is disposed between the first emission portion and the second emission portion and transmits external light. A second transmission portion may be disposed between the second emission portion and the third emission portion and may emit external light.

[0017] The second electrode may extend to regions corresponding to the second emission portion, the third emission portion, the first transmission portion, and the second transmission portion.

[0018] The second electrode may extend to regions corresponding to the second emission portion and the third emission portion, and may include openings corresponding to the first transmission portion and the second transmission portion.

[0019] The optical member may include a high refractive index layer and a low refractive index layer that are alternately stacked.

[0020] The high refractive index layer and the low refractive index layer may have a refractive index of about 1.3 to about 2.3, and a difference of the refractive index between the high refractive index layer and the low refractive index layer may be in the range of about 0.1 to about 1.

[0021] The optical member may include a block copolymer.

[0022] The block copolymer may be polystyrene-block-poly(methylmethacrylate) (PS-b-PMMA), polystyrene-block-poly(ethylene oxide) (PS-b-PEO), polystyrene-block-poly(vinyl pyridine) (PS-b-PVP), polystyrene-block-poly(ethylene-alt-propylene) (PS-b-PEP), and/or polystyrene-block-polyisoprene (PS-b-PI).

[0023] The first color, the second color, and the third color may correspond to a red color, a green color, and a blue color, respectively.

BRIEF DESCRIPTION OF THE DRAWINGS

[0024] These and/or other aspects will become apparent and more readily appreciated from the following description of the embodiments, taken in conjunction with the accompanying drawings of which:

[0025] FIG. 1 is a schematic plan view of an organic light-emitting display apparatus according to an exemplary embodiment of the present invention;

[0026] FIG. 2 is a cross-sectional view taken along a line II-II of FIG. 1;

[0027] FIG. 3 is a schematic plan view of an organic light-emitting display apparatus according to an exemplary embodiment of the present invention;

[0028] FIG. 4 is a schematic plan view of an organic light-emitting display apparatus according to an exemplary embodiment of the present invention;

[0029] FIG. 5 is a schematic cross-sectional view of an organic light-emitting device according to an exemplary embodiment of the present invention;

[0030] FIG. 6 is a schematic cross-sectional view of an organic light-emitting device according to an exemplary embodiment of the present invention;

[0031] FIG. 7 is a schematic cross-sectional view of an organic light-emitting device according to an exemplary embodiment of the present invention;

[0032] FIG. 8 is a schematic cross-sectional view of an organic light-emitting device according to an exemplary embodiment of the present invention;

[0033] FIG. 9 is a schematic cross-sectional view illustrating an operation of the organic light-emitting display apparatus of FIG. 1;

[0034] FIG. 10 is a schematic cross-sectional view of an optical member included in the organic light-emitting display apparatus of FIG. 1;

[0035] FIG. 11 is a graph illustrating a transmittance of the optical member of FIG. 10 with respect to a wavelength;

[0036] FIG. 12 is a phase equilibrium diagram of a block copolymer;

[0037] FIG. 13 is a schematic diagram of nanostructures according to a volume ratio of the block copolymer of FIG. 12; and

[0038] FIG. 14 is a graph illustrating a reflectance of the optical member including the block copolymer of FIG. 12 with respect to a wavelength.

DETAILED DESCRIPTION

[0039] In describing exemplary embodiments of the present disclosure illustrated in the drawings, specific terminology is employed for sake of clarity. However, the present disclosure is not intended to be limited to the specific terminology so selected, and it is to be understood that each specific element includes all technical equivalents which operate in a similar manner.

[0040] Throughout the disclosure, like reference numerals may refer to like parts, and a redundant description thereof may therefore be limited or omitted.

[0041] It will be understood that although the terms “first”, “second”, etc. may be used herein to describe various components, these components should not be limited by these terms. These components are only used to distinguish one component from another.

[0042] It will be understood that when a layer, region, or component is referred to as being “formed on,” another layer, region, or component, it can be directly formed on the other layer, region, or component or intervening elements such as layers, regions and/or components may be present.

[0043] Sizes of elements in the drawings may be exaggerated for clarity and convenience of explanation.

[0044] FIG. 1 is a schematic plan view of an organic light-emitting display apparatus 100 according to an exemplary embodiment of the present invention, and FIG. 2 is a cross-sectional view taken along a line II-II of FIG. 1.

[0045] Referring to FIGS. 1 and 2, the organic light-emitting display apparatus 100 according to an exemplary embodiment of the present invention may include a first emission portion PA1 emitting light of a first color, a second emission portion PA2 emitting light of a second color, and a third emission portion PA3 emitting light of a third color, all of which may be disposed not to overlap one another. The emission portions PA1, PA2 and PA3 include organic light-emitting devices including first electrodes 121a, 121b and 121c, intermediate layers 123a, 123b and 123c, and second electrodes 125, respectively, which are sequentially disposed on a thin film transistor (TFT) array substrate 110. The emission portions PA1, PA2 and PA3 may be partitioned by pixel defining layers (PDLs) 122.

[0046] The first intermediate layer 123a included in the first emission portion PA1, the second intermediate layer 123b included in the second emission portion PA2, and the third intermediate layer 123c included in the third emission portion PA3 each include organic emission layers emitting lights of different colors, respectively. In addition, the intermediate layers 123a, 123b, 123c may further include a hole injection layer (HIL), a hole transport layer (HTL), an electron transport layer (ETL), and/or an electron injection layer (EIL). The embodiment of the present invention is not limited thereto, and the intermediate layers 121a, 121b and 121c may include organic emission layers and various function layers.

[0047] Lights emitted from the intermediate layers 123a, 123b and 123c may pass through the first electrodes 121a, 121b and 121c and the second electrodes 125 provided as transparent or translucent electrodes.

[0048] The first electrodes **121a**, **121b** and **121c** may include indium tin oxide (ITO), indium zinc oxide (IZO), zinc oxide (ZnO), indium oxide (In_2O_3), indium gallium oxide (IGO), and/or aluminum zinc oxide (AZO). The second electrodes **125** may be formed of a metal having a low work function, for example, silver (Ag), magnesium (Mg), aluminum (Al), platinum (Pt), palladium (Pd), gold (Au), nickel (Ni), neodymium (Nd), iridium (Ir), chromium (Cr), lithium (Li), calcium (Ca), ytterbium (Yb), or any alloys thereof. In this case, the second electrodes **125** may be formed of high-transmittance thin films that have a thickness range of about 100 Å to about 300 Å.

[0049] The first electrodes **121a**, **121b** and **121c** and the second electrodes **125** may each have high transmittance. Therefore, the organic light-emitting display apparatus **100** according to exemplary embodiments of the present invention may have high transmittance with respect to external light.

[0050] The organic light-emitting display apparatus **100** according to exemplary embodiment of the present invention includes an optical member **130** disposed under the TFT array substrate **110**.

[0051] The optical member **130** may reflect only lights of wavelengths corresponding to a first color, a second color, and a third color, and transmit light of the other wavelengths. For example, the light of the first color emitted from the first intermediate layer **123a**, the light of the second color emitted from the second intermediate layer **123b**, and the light of the third color emitted from the third intermediate layer **123c** partially pass through the first electrodes **121a**, **121b** and **121c** and are incident on the TFT array substrate **110**, and light passing through the TFT array substrate **110** is incident on the optical member **130**.

[0052] The optical member **130** functions as a reflection plate with respect to only a particular color to reflect incident light of the particular color, and the reflected light passes through the second electrodes **125**. In this manner, an image is displayed.

[0053] For example, while some reflection films have been employed in the first electrodes **121a**, **121b** and **121c** or the second electrodes **125** so as to reduce light loss, there has been a limitation in increasing the transmittance of the organic light-emitting display apparatus. However, the organic light-emitting display apparatus **100** according to exemplary embodiments of the present invention employs the optical member **130** that reflects only light of particular wavelengths, without any reflection films. Therefore, the transmittance of the organic light-emitting display apparatus **100** may be increased, and the light loss may be reduced.

[0054] The first color, the second color, and the third color may correspond to a red color, a green color, and a blue color, respectively, but the present invention is not limited thereto. For example, various color combinations other than the combination of the red, green and blue colors may be used as long as the colors can combine to produce light that is substantially white.

[0055] The TFT array substrate **110** includes a transparent substrate **111**, and circuit portions PC1, PC2 and PC3 disposed on the transparent substrate **111** and includes at least one TFT.

[0056] The organic light-emitting display apparatus **100** according to exemplary embodiments of the present embodiment may include the first circuit portion PC1, the second circuit portion PC2, and the third circuit portion PC3 electri-

cally connected to the first emission portion PA1, the second emission portion PA2, and the third emission portion PA3, respectively, and disposed to overlap the respective emission portions PA1, PA2 and PA3.

[0057] Although not illustrated, the respective circuit portions PC1, PC2 and PC3 may further include additional TFTs and capacitor as well as first to third driving TFTs T1, T2 and T3 electrically connected to the first electrodes **121a**, **121b** and **121c** of the organic light-emitting device.

[0058] The first driving TFT T1 may include a first active layer **113a**, a first gate electrode **115a**, a first source electrode **118a**, and a first drain electrode **117a**, and the second driving TFT T2 may include a second active layer **113a**, a second gate electrode **115b**, a second source electrode **118b**, and a second drain electrode **117b**.

[0059] In detail, referring to FIG. 2, a buffer layer **112** is disposed on the substrate **111**, and the first active layer **113a** and the second active layer **113b** are disposed on the buffer layer **112**.

[0060] The buffer layer **112** serves to prevent penetration of impurities and perform surface planarization. The buffer layer **112** may be formed of various materials that perform such functions. For example, the buffer layer **112** may be formed of an inorganic material, such as silicon oxide, silicon nitride, silicon oxynitride, aluminum oxide, aluminum nitride, titanium oxide, and/or titanium nitride, and/or an organic material, such as polyimide, polyester, or acryl, and/or any stacks thereof. The buffer layer may be optionally omitted.

[0061] The active layers **113a** and **113b** may be formed to include various materials. For example, the active layers **113a** and **113b** may include an inorganic semiconductor material, such as amorphous silicon or crystalline silicon. As another example, the active layers **113a** and **113b** may include an oxide semiconductor. As another example, the active layers **113a** and **113b** may include organic semiconductor materials.

[0062] A gate insulating layer **114** is disposed on the buffer layer **112** to cover the active layers **113a** and **113b**, and gate electrodes **115a** and **115b** are disposed on the gate insulating layer **114**.

[0063] An interlayer insulating layer **116** is disposed on the gate insulating layer **114** to cover the gate electrodes **115a** and **115b**. Source electrodes **118a** and **118b** and drain electrodes **117a** and **117b** are disposed on the interlayer insulating layer **116** and are electrically connected to the active layers **113a** and **113b** through contact holes.

[0064] A passivation layer **119** is disposed on the interlayer insulating layer **116** to cover the source electrodes **118a** and **118b** and the drain electrodes **117a** and **117b**. The drain electrodes **117a** and **117b** are electrically connected to the first electrodes **121a** and **121b** through via holes.

[0065] The structure of the TFTs T1 and T2 is not limited to the above examples, and various structures may also be applied to the TFTs T1 and T2.

[0066] FIG. 3 is a schematic plan view of an organic light-emitting display apparatus **200** according to an exemplary embodiment of the present invention.

[0067] Referring to FIG. 3, the organic light-emitting display apparatus **200** according to exemplary embodiments of the present invention includes a first emission portion PA1, a second emission portion PA2, and a third emission portion PA3. The emission portions PA1, PA2 and PA3 include first electrodes **221a**, **221b** and **221c**, intermediate layers **223a**,

223b and **223c** emitting light of a first color, light of a second color, and light of a third color, and second electrodes **225**, respectively.

[0068] The organic light-emitting display apparatus **200** according to an exemplary embodiment of the present invention may include a first circuit portion **PC1**, a second circuit portion **PC2**, and a third circuit portion **PC3** electrically connected to the first emission portion **PA1**, the second emission portion **PA2**, and the third emission portion **PA3**, respectively, and disposed not to overlap the respective emission portions **PA1**, **PA2** and **PA3**.

[0069] The circuit portions **PC1**, **PC2** and **PC3** include a plurality of TFTs, at least one capacitor, and wirings. The electrodes or wirings may be formed using only transparent materials, where desired.

[0070] In the organic light-emitting display apparatus **200** according to exemplary embodiments of the present invention, lights emitted from the intermediate layers **223a**, **223b** and **223c** pass through the first electrodes **221a**, **221b** and **221c**, are incident on the TFT array substrate (**110** in FIG. 2), and are reflected by the optical member **230**.

[0071] In this case, if the circuit portions **PC1**, **PC2** and **PC3** are disposed to overlap the emission portions **PA1**, **PA2** and **PA3**, traveling light may be partially reflected by the electrodes and wirings, or a path of the light may be changed.

[0072] However, in the organic light-emitting display apparatus **200** according to exemplary embodiment of the present invention, since the circuit portions **PC1**, **PC2** and **PC3** are disposed not to overlap the emission portions **PA1**, **PA2** and **PA3**, the electrodes or the like do not affect the path of the light. Hence, the optical efficiency and transmittance of the organic light-emitting display apparatus may be increased.

[0073] FIG. 4 is a schematic plan view of an organic light-emitting display apparatus **300** according to an exemplary embodiment of the present invention.

[0074] Referring to FIG. 4, the organic light-emitting display apparatus **300** according to exemplary embodiments of the present invention includes a first emission portion **PA1**, a second emission portion **PA2**, and a third emission portion **PA3**. The emission portions **PA1**, **PA2** and **PA3** include first electrodes **321a**, **321b** and **321c**, intermediate layers **323a**, **323b** and **323c** emitting light of a first color, light of a second color, and light of a third color, and second electrodes **325**, respectively.

[0075] The organic light-emitting display apparatus **300** according to exemplary embodiments of the present invention may include a first circuit portion **PC1**, a second circuit portion **PC2**, and a third circuit portion **PC3** electrically connected to the first emission portion **PA1**, the second emission portion **PA2**, and the third emission portion **PA3**, respectively. The organic light-emitting display apparatus **300** according to exemplary embodiments of the present invention may further include a first transmission portion **TA1** disposed between the first emission portion **PA1** and the second emission portion **PA2** and transmitting external light, a second transmission portion **TA2** disposed between the second emission portion **PA2** and the third emission portion **PA3** and transmitting external light, and a third transmission portion **TA3** disposed adjacent to the third emission portion **PA3**.

[0076] The first electrodes **321a**, **321b** and **321c** and the intermediate layers **323a**, **323b** and **323c** are not disposed in the transmission portions **TA1**, **TA2** and **TA3**. The second electrodes **325** serve as a common electrode and extend to regions corresponding to the first transmission portion **PA1**,

the second emission portion **PA2**, the third emission portion **PA3**, the first transmission portion **TA1**, the second transmission portion **TA2**, and the third transmission portion **TA3**.

[0077] Since the intermediate layers **323a**, **323b** and **323c** are not disposed in the transmission portions **TA1**, **TA2** and **TA3**, the transmission portions **TA1**, **TA2** and **TA3** do not emit light, but transmit external light. Therefore, the transmission portions **TA1**, **TA2** and **TA3** serve to increase the transmittance of the organic light-emitting display apparatus **300** with respect to the external light.

[0078] Although not illustrated, the second electrodes included in the organic light emitting display apparatus according to exemplary embodiments of the present invention may extend to regions corresponding to the first emission portion **PA1**, the second emission portion **PA2**, and the third emission portion **PA3**, and may include openings corresponding to the first transmission portion **TA1**, the second transmission portion **TA2**, and the third transmission portion **TA3**.

[0079] In addition, openings may be formed in the insulating layers (for example, the pixel defining layer **122** and the passivation layer **119**) disposed in the regions corresponding to the first transmission portion **TA1**, the second transmission portion **TA2**, and the third transmission portion **TA3**.

[0080] In this manner, external light transmittance in the transmission portions **TA1**, **TA2** and **TA3** may be increased, and thus, the transmittance of the organic light-emitting display apparatus may be increased.

[0081] FIG. 5 is a schematic cross-sectional view of a first organic light-emitting device according to an exemplary embodiment of the present invention. FIG. 6 is a schematic cross-sectional view of a second organic light-emitting device according to an exemplary embodiment of the present invention. FIG. 7 is a schematic cross-sectional view of a third organic light-emitting device according to an exemplary embodiment of the present invention. FIG. 8 is a schematic cross-sectional view of a fourth organic light-emitting device according to an exemplary embodiment of the present invention. Each of these first through fourth organic light-emitting devices represent different structures, however, exemplary embodiments of the present invention contemplate combining elements of these distinct organic light-emitting devices to produce additional embodiments.

[0082] Referring to FIG. 5, the first organic light-emitting device includes a first electrode **121**, an intermediate layer **123**, and a second electrode **125**. An optical member **130** is disposed under the first electrode **121**, and a substrate **110** is disposed between the first electrode **121** and the optical member **130**.

[0083] The intermediate layer **123** may include an organic emission layer emitting a single color such as a red color, a green color, or a blue color. The optical member **130** may selectively reflect light of a wavelength corresponding to the color emitted from the organic emission layer.

[0084] Alternatively, the intermediate layer **123** may emit white light. The intermediate layer **123** emitting the white light may have various structures. For example, the intermediate layer **123** may have a stacked structure of at least a light-emitting material emitting red light, a light-emitting material emitting green light, and a light-emitting material emitting blue light.

[0085] As an example for emitting the white light, the intermediate layer **123** may have a combined structure of at least

a light-emitting material emitting red light, a light-emitting material emitting green light, and a light-emitting material emitting blue light.

[0086] In this case, the optical member 130 may selectively reflect light of wavelengths corresponding to the red color, the green color, and the blue color.

[0087] The first electrode 121 and the second electrode 125 transmit light, and the optical member 130 functions as a reflection plate with respect to a particular color. Therefore, light may be finally emitted in a direction of the second electrode 125. For example, the organic light-emitting display apparatus including the first organic light-emitting device may be a top emission type display apparatus that implements an image in a direction of the second electrode 125.

[0088] Referring to FIG. 6, the second organic light-emitting device includes a first electrode 121, an intermediate layer 123, and a second electrode 125. An optical member 130 is disposed under the first electrode 121, and a substrate 110 is disposed under the optical member 130.

[0089] The first electrode 121 and the second electrode 125 transmit light. The optical member 130 may reflect only light of a particular wavelength among light emitted from the organic emission layer included in the intermediate layer 123, and may transmit lights of other wavelengths.

[0090] Here, since the light of the particular wavelength reflected from the optical member 130 is not incident in the substrate 101, the light may not be reflected by electrodes and wirings or the like that may be disposed in the substrate 101, and the path of the light may not be changed. Light loss may be reduced because a distance between the intermediate layer 123 and the optical member 130 is short.

[0091] Referring to FIG. 7, the third organic light-emitting device includes a first electrode 121, an intermediate layer 123, and a second electrode 125. A substrate 110 is disposed under the first electrode 121, and an optical member 130 is disposed on the second electrode 125. The substrate 110 may be a TFT array substrate including TFTs.

[0092] The first electrode 121 and the second electrode 125 transmit light, and the optical member 130 functions as a reflection plate with respect to a particular color. Therefore, the light may be finally emitted in a direction of the first electrode 121. For example, the organic light-emitting display apparatus including the organic light-emitting device 30 may be a bottom emission type display apparatus that implements an image in a direction of the first electrode 121.

[0093] Although not illustrated, an encapsulation layer may be disposed on the optical member 130 or between the second electrode 125 and the optical member 130.

[0094] Referring to FIG. 8, the fourth organic light-emitting device includes a first electrode 121, an intermediate layer 123, and a second electrode 125. A transparent substrate 111 and a circuit portion PC may be disposed under the first electrode 121, and an optical member 130 may be disposed between the transparent substrate 111 and the circuit portion PC.

[0095] FIG. 9 is a schematic cross-sectional view illustrating an operation of the organic light-emitting display apparatus of FIG. 1, FIG. 10 is a schematic cross-sectional view of the optical member included in the organic light-emitting display apparatus of FIG. 1, and FIG. 11 is a graph illustrating a transmittance of the optical member of FIG. 10 with respect to a wavelength.

[0096] Referring to FIG. 9, the organic light-emitting display apparatus 100 according to an exemplary embodiment of the present embodiment includes a first emission portion PA1, a second emission portion PA2, and a third emission portion PA3. The transmission portions PA1, PA2 and PA3 may include first electrodes 121a, 121b and 121c, intermediate layers 123a, 123b and 123c, and a second electrode 125.

[0097] The first emission portion PA1, the second emission portion PA2, and the third emission portion PA3 may emit light of a first color, light of a second color, and light of a third color, respectively. The light of the first color, the light of the second color, and the light of the third color may be red light, green light, and blue light, respectively.

[0098] A substrate 110 is disposed under the emission portions PA1, PA2 and PA3, and an optical member 130 is disposed under the substrate 110. An encapsulation layer 140 may be disposed on the emission portions PA1, PA2 and PA3.

[0099] Referring to FIG. 10, the optical member 130 may include a first color light reflection portion 131, a second color light reflection portion 132, and a third color light reflection portion 133, and may include a high refractive index layer H and a low refractive index layer L stacked alternately in a repeating pattern.

[0100] The stacked structure of the high refractive index layer H and the low refractive index layer L may be formed using a block copolymer, which will be described below.

[0101] The high refractive index layer H and the low refractive index layer L may have a refractive index of about 1.3 to about 2.3, and a difference between the high refractive index layer H and the low refractive index layer L may be in the range of about 0.1 to about 1.

[0102] The optical member 130 may be designed to reflect only light of a particular wavelength. The optical member 130 may reflect light of a desired wavelength by adjusting a period (L_0) and a refractive index (n) according to Equation 1 below. The refractive index may be adjusted according to a difference of the refractive index between the high refractive index layer H and the low refractive index layer L and the number of stacks thereof.

$$L_0/2 = \lambda/4n \quad \text{[Equation 1]}$$

[0103] FIG. 11 illustrates a transmittance of the optical member 130 with respect to a wavelength. In this case, a period (L_0) of the second color light reflection portion 132 is about 142 nm. Based on this, a period of the first color light reflection portion 131 is about 1.19 L_0 , a period of the third color light reflection portion 133 is about 0.82 L_0 , and each of the first to third color light reflection portions 131 to 133 has a total thickness of 3 μm .

[0104] For example, FIG. 11 is a simulation result showing the transmittance of the optical member 130 with respect to the wavelength in a condition satisfying the following optical structure.

$$\text{Glass}/0.82(LH)^m(LH)^n1.19(LH)^o/\text{Air}$$

[0105] where m, n and o represent the number of stacks of the high refractive index layer H and the low refractive index layer L included in the third color light reflection portion 133, the second color light reflection portion 132, and the first color light reflection portion 131, respectively, and may be calculated by dividing the total thickness (about 3 μm) by the period of the corresponding color light reflection portions 131, 132 and 133.

[0106] As can be seen from the graph, the optical member 130 has a transmission of about zero at about 450 nm corre-

sponding to the blue color, about 550 nm corresponding to the green color, and about 650 nm corresponding to the red color. That is, the optical member 130 has high reflectance at only wavelengths corresponding to the blue color, the green color, and the red color, and has high transmittance with respect to lights of other wavelengths.

[0107] Even though a half-width of light emitted from the intermediate layers 123a, 123b and 123c is slightly wide, the optical member 130 selectively reflecting only light of a particular color serves as a filter. Therefore, the organic light-emitting display apparatus 100 according to exemplary embodiments of the present invention may emit light having a narrow half-width, for example, light having high color purity.

[0108] Referring again to FIGS. 9 and 10, the red light emitted from the first intermediate layer 123a included in the first emission portion PA1 may be reflected from the first color light reflection portion 131 of the optical member 130, the green light emitted from the second intermediate layer 123b included in the second emission portion PA2 may be reflected from the second color light reflection portion 132 of the optical member 130, and the blue light emitted from the third intermediate layer 123c included in the third emission portion PA3 may be reflected from the third color light reflection portion 133 of the optical member 130.

[0109] In this case, light other than the red light, the green light, and the blue light are not reflected but transmitted in the optical member 130. When viewed in a direction of the encapsulation layer 140, external light incident in a direction of the optical member 130 is directly transmitted. When viewing the organic light-emitting display apparatus 100, a background disposed on a backside of the organic light-emitting display apparatus 100 is viewed as it is. Therefore, it is possible to implement the transparent organic light-emitting display apparatus 100 with high transmittance.

[0110] In addition, since only the light of the particular color is selectively reflected by the optical member 130, it is possible to implement the organic light-emitting display apparatus 100 with increased color purity.

[0111] The optical member 130 of the organic light-emitting display apparatus 100 of FIG. 9 is disposed in an entire surface to correspond to the first emission portion PA1, the second emission portion PA2, and the third emission portion PA3, but the present invention is not limited thereto. The optical member of the organic light-emitting display apparatus according to exemplary embodiments of the present invention may be disposed in an island shape to correspond to the first emission portion PA1, the second emission portion PA2, and the third emission portion PA3. In this case, the optical member may be designed to reflect only light of the wavelength emitted from the emission portion disposed in the corresponding region.

[0112] FIG. 12 is a phase equilibrium diagram of a block copolymer, FIG. 13 is a schematic diagram of nanostructures according to a volume ratio of the block copolymer of FIG. 12, and FIG. 14 is a graph illustrating a reflectance of the optical member including the block copolymer of FIG. 12 with respect to a wavelength.

[0113] The optical members 130, 230 and 330 included in the organic light-emitting display apparatuses 100, 200 and 300 according to exemplary embodiments of the present invention may include a block copolymer.

[0114] The block copolymer refers to a polymer formed by linearly connecting a plurality of blocks in such a manner that

a block is formed by polymerizing one type of monomer and a block is formed by polymerizing another type of monomer.

[0115] The block copolymer may include polystyrene-block-poly(methylmethacrylate) (PS-b-PMMA), polystyrene-block-poly(ethylene oxide) (PS-b-PEO), polystyrene-block-poly(vinyl pyridine) (PS-b-PVP), polystyrene-block-poly(ethylene-alt-propylene) (PS-b-PEP), and/or polystyrene-block-polyisoprene (PS-b-PI), and may have a self-assembly characteristic.

[0116] FIG. 12 is a phase equilibrium diagram of PS-b-PMMA. PS-b-PMMA includes two materials, for example, a high refractive index material and a low refractive index material. In the phase equilibrium diagram, a horizontal axis f_A represents a volume ratio of the high refractive index material with respect to a total volume, and a vertical axis (χn) represents the product of a repulsive force (χ) and a degree of polymerization (N).

[0117] FIG. 13 illustrates various nanostructures of the PS-b-PMMA according to the volume ratio f_A . In a region L of FIG. 12, a nanostructure, in which two materials, for example, a high refractive index material and a low refractive index material, are alternately and repeatedly stacked as illustrated in FIG. 13, is formed.

[0118] The stacked structure of the high refractive index material and the low refractive index material may also be applied to the optical members 100, 200 and 300 included in the organic light-emitting display apparatuses 100, 200 and 300 according to exemplary embodiments of the present invention.

[0119] Referring to FIG. 14, after the nanostructure of the block copolymer is stacked on the substrate, the reflectance according to the wavelength is measured. A simulation result Sim and measured results #1, #2, #3 and #4 are compared with one another.

[0120] In this case, the simulation may be performed under the following conditions: the high refractive index layer H has a refractive index of 1.7 and a thickness of 31.887 nm, the low refractive index layer L has a refractive index of 1.5 and a thickness of 31.887, a total thickness thereof is 382.64 nm, an optical structure is L(HL)⁵H, a block copolymer used in the experiment is PS-b-PMMA, and a period L_0 thereof is 62 nm.

[0121] The measured result may be similar to the simulation result. This represents that the nanostructure of the block copolymer has a desired optical structure, for example, a stacked structure of a high refractive index layer and a low refractive index layer, and an optical member can be formed using the block copolymer.

[0122] As described above, the organic light-emitting display apparatuses according to exemplary embodiments of the present invention may be configured to transmit light, without employing the reflection film in the first electrode or the second electrode. In addition, by employing the optical member reflecting only lights of particular colors, the transmittance and color purity of the organic light-emitting display apparatuses may be increased, and light loss may be reduced.

[0123] Moreover, the optical member may be formed using the block copolymer.

[0124] As described above, the organic light-emitting display apparatuses may reduce light loss and may have high transmittance and color purity.

[0125] It should be understood that the exemplary embodiments described herein should be considered in a descriptive sense only and not for purposes of limitation. Descriptions of

features or aspects within each embodiment should typically be considered as available for other similar features or aspects in other embodiments.

[0126] While one or more embodiments of the present invention have been described with reference to the figures, it will be understood by those of ordinary skill in the art that various changes in form and details may be made therein without departing from the spirit and scope of the present invention.

What is claimed is:

1. An organic light-emitting display apparatus comprising: a first emission portion comprising a first intermediate layer, a first electrode disposed on a first surface of the first intermediate layer and transmits light emitted from the first intermediate layer, and a second electrode disposed on a second surface of the first intermediate layer that faces the first surface of the first intermediate layer and transmits light emitted from the first intermediate layer, the first emission portion being configured to emit light of a first color; and an optical member disposed on a first surface of the first emission portion and selectively reflecting lights of particular colors including at least the first color.
2. The organic light-emitting display apparatus of claim 1, further comprising: a second emission portion, disposed adjacent to the first emission portion, without overlapping the first emission portion, comprises a second intermediate layer, the second emission portion being configured to emit light of a second color; and a third emission portion, disposed adjacent to the second emission portion, without overlapping the first emission portion and the second emission portion, comprises a third intermediate layer, the third emission portion being configured to emit light of a third color, wherein the optical member extends from the first emission portion to the second emission portion and the third emission portion, and selectively reflects the light of the first color, the light of the second color, and the light of the third color.
3. The organic light-emitting display apparatus of claim 1, wherein the first electrode comprises indium tin oxide (ITO), indium zinc oxide (IZO), zinc oxide (ZnO), indium oxide (In_2O_3), indium gallium oxide (IGO), or aluminum zinc oxide (AZO) as a material transmitting the light emitted from the first emission portion, and the second electrode comprises a magnesium (Mg) thin film, a silver (Ag) thin film, or an Mg:Ag thin film as a material transmitting light emitted from the first emission portion.
4. The organic light-emitting display apparatus of claim 1, wherein a substrate is disposed between the first electrode and the optical member.
5. The organic light-emitting display apparatus of claim 1, wherein a substrate is disposed on an opposite surface to a surface of the first electrode where the first intermediate layer is disposed, and the optical member is disposed between the first electrode and the substrate.
6. The organic light-emitting display apparatus of claim 1, wherein a thin film transistor (TFT) array substrate is disposed on an opposite surface to a surface of the first electrode where the first intermediate layer is disposed,

the TFT array substrate comprises a transparent substrate and a circuit portion, the circuit portion being disposed on the transparent substrate and comprising a TFT, and the optical member is disposed between the transparent substrate and the circuit portion.

7. The organic light-emitting display apparatus of claim 1, wherein a TFT array substrate is disposed on an opposite surface to a surface of the first electrode where the first intermediate layer is disposed, and

the optical member is disposed on an opposite surface to a surface of the second electrode where the first intermediate layer is disposed.

8. The organic light-emitting display apparatus of claim 2, wherein the optical member comprises a first color light reflection portion, a second color light reflection portion, and a third color light reflection portion.

9. The organic light-emitting display apparatus of claim 2, further comprising a first circuit portion, a second circuit portion, and a third circuit portion electrically connected to the first emission portion, the second emission portion, and the third emission portion, respectively,

wherein none of the first circuit portion, the second circuit portion, and the third circuit portion are disposed to overlap any of the first emission portion, the second emission portion, or the third emission portion.

10. The organic light-emitting display apparatus of claim 2, further comprising a first circuit portion, a second circuit portion, and a third circuit portion electrically connected to the first emission portion, the second emission portion, and the third emission portion, respectively,

wherein the first circuit portion, the second circuit portion, and the third circuit portion are disposed to overlap the first emission portion, the second emission portion, and the third emission portion, respectively.

11. The organic light-emitting display apparatus of claim 2, further comprising:

a first transmission portion, disposed between the first emission portion and the second emission portion, transmitting external light; and

a second transmission portion, disposed between the second emission portion and the third emission portion, emitting external light.

12. The organic light-emitting display apparatus of claim 11, wherein the second electrode extends to regions corresponding to the second emission portion, the third emission portion, the first transmission portion, and the second transmission portion.

13. The organic light-emitting display apparatus of claim 11, wherein the second electrode extends to regions corresponding to the second emission portion and the third emission portion, and comprises openings corresponding to the first transmission portion and the second transmission portion.

14. The organic light-emitting display apparatus of claim 1, wherein the optical member comprises a high refractive index layer and a low refractive index layer that are alternately and repeatedly stacked.

15. The organic light-emitting display apparatus of claim 14, wherein the high refractive index layer and the low refractive index layer each have a refractive index of about 1.3 to about 2.3, and a difference of the refractive index between the high refractive index layer and the low refractive index layer is in a range of about 0.1 to about 1.

16. The organic light-emitting display apparatus of claim **14**, wherein the optical member comprises a block copolymer.

17. The organic light-emitting display apparatus of claim **16**, wherein the block copolymer includes polystyrene-block-poly(methylmethacrylate) (PS-b-PMMA), polystyrene-block-poly(ethylene oxide) (PS-b-PEO), polystyrene-block-poly(vinyl pyridine) (PS-b-PVP), polystyrene-block-poly(ethylene-alt-propylene) (PS-b-PEP), or polystyrene-block-polyisoprene (PS-b-PI).

18. The organic light-emitting display apparatus of claim **2**, wherein the first color, the second color, and the third color correspond to a red color, a green color, and a blue color, respectively.

19. A transparent organic light-emitting display apparatus, comprising:

a first light emission portion emitting light of a first color and having electrodes that are substantially transparent;

a second light emission portion emitting light of a second color and having electrodes that are substantially transparent;

a third light emission portion emitting light of a third color and having electrodes that are substantially transparent, wherein the first, second and third light emission portions do not overlap each other; and

an optical member disposed below the first, second, and third light emission portions,

wherein the optical member is configured to reflect substantially all light of the first, second and third color and transmit substantially all light of colors other than the first, second or third color.

20. The transparent organic light-emitting display apparatus of claim **19**, wherein a substrate layer is disposed between the optical member and at least one electrode of the electrodes of each of the first, second, and third light emission portions.

* * * * *

专利名称(译)	有机发光显示装置		
公开(公告)号	US20150041768A1	公开(公告)日	2015-02-12
申请号	US14/153960	申请日	2014-01-13
[标]申请(专利权)人(译)	三星显示有限公司		
申请(专利权)人(译)	三星DISPLAY CO. , LTD.		
当前申请(专利权)人(译)	三星DISPLAY CO. , LTD.		
[标]发明人	YOU JAE HO KIM MYUNG IM PARK SEUNG WON XIE LEI LEE MOON GYU LEE SU MI		
发明人	YOU, JAE-HO KIM, MYUNG-IM PARK, SEUNG-WON XIE, LEI LEE, MOON-GYU LEE, SU-MI		
IPC分类号	H01L27/32		
CPC分类号	H01L27/3262 H01L27/3211 H01L27/326 H01L51/504 H01L51/5271 H01L2251/5323 H01L51/5275		
优先权	1020130095607 2013-08-12 KR		
其他公开文献	US9202850		
外部链接	Espacenet USPTO		

摘要(译)

有机发光显示装置包括第一发光部分和光学构件。第一发光部分发射第一颜色的光，并且包括第一中间层，设置在第一中间层的一个表面上并透射从第一中间层发射的光的第一电极，以及设置在第一中间层上的第二电极。第一中间层的另一表面面向第一中间层的一个表面，并透射从第一中间层发射的光。光学构件设置在第一发光部分的一个表面上，并选择性地反射包括至少第一颜色光的特定颜色的光。

